



HIGH POINT INDUSTRIAL



Precise Saw Wheel Elevation

- The saw wheel elevation is transmitted through precision ball screw, providing minimum backlash while assuring outstanding saw wheel positioning accuracy.



Centralized Control Panel

- All electric controls of the machine are centralized on one control panel for convenience.
- Digital thickness controller provides quick and accurate saw head positioning.
- An Amp meter is provided on the control panel to show the exact amount of saw wheel motor horsepower being used during operation. This protects the motor from burning out.



Correct Blade Tension Indication

- The saw blade tension is controlled by a hydraulic cylinder for positive tension control at all times.
- A tension gauge is provided on the hydraulic tension control system for accurately setting blade tension.

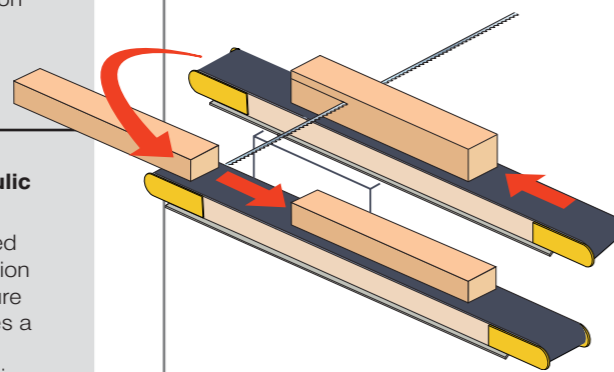

Blade Tension By Air/Hydraulic Combination (Optional)

- The blade tension is controlled by an air/ hydraulic combination unit. In case hydraulic pressure drops, the air system provides a pressure compensation to ensure a constant blade tension at all time.



Oil Mist Lubricator

- The machine is available to equip with an oil mist lubricator to prevent chips form depositing on the blade. The lubricator also effectively extends the blade service life.



Touch-Sensing Screen (Optional)

- Upon request, the centralized control panel is available to equip with a touch-sensing screen for upgrading operation convenience.

www.highpointinc.com



HIGH POINT INDUSTRIAL CORP.

6116 Paramount Blvd., City of Long Beach, CA 90801 U.S.A.
 TOLL FREE: 1-888-237-1752
 TEL: 1-562-630-1803 FAX: 1-562-633-0161
 E-mail: roger@highpointinc.com

BLUE STEEL

BLUE STEEL MACHINERY CO.

86-10, Shen Ching Road, Ching Shui, Taiwan 43641
 TEL : +886-4-2620-1608 FAX : +886-4-2620-0289
 E-mail : bsm168@ms62.hinet.net
www.highpointinc.com



Single Head Band Resaw

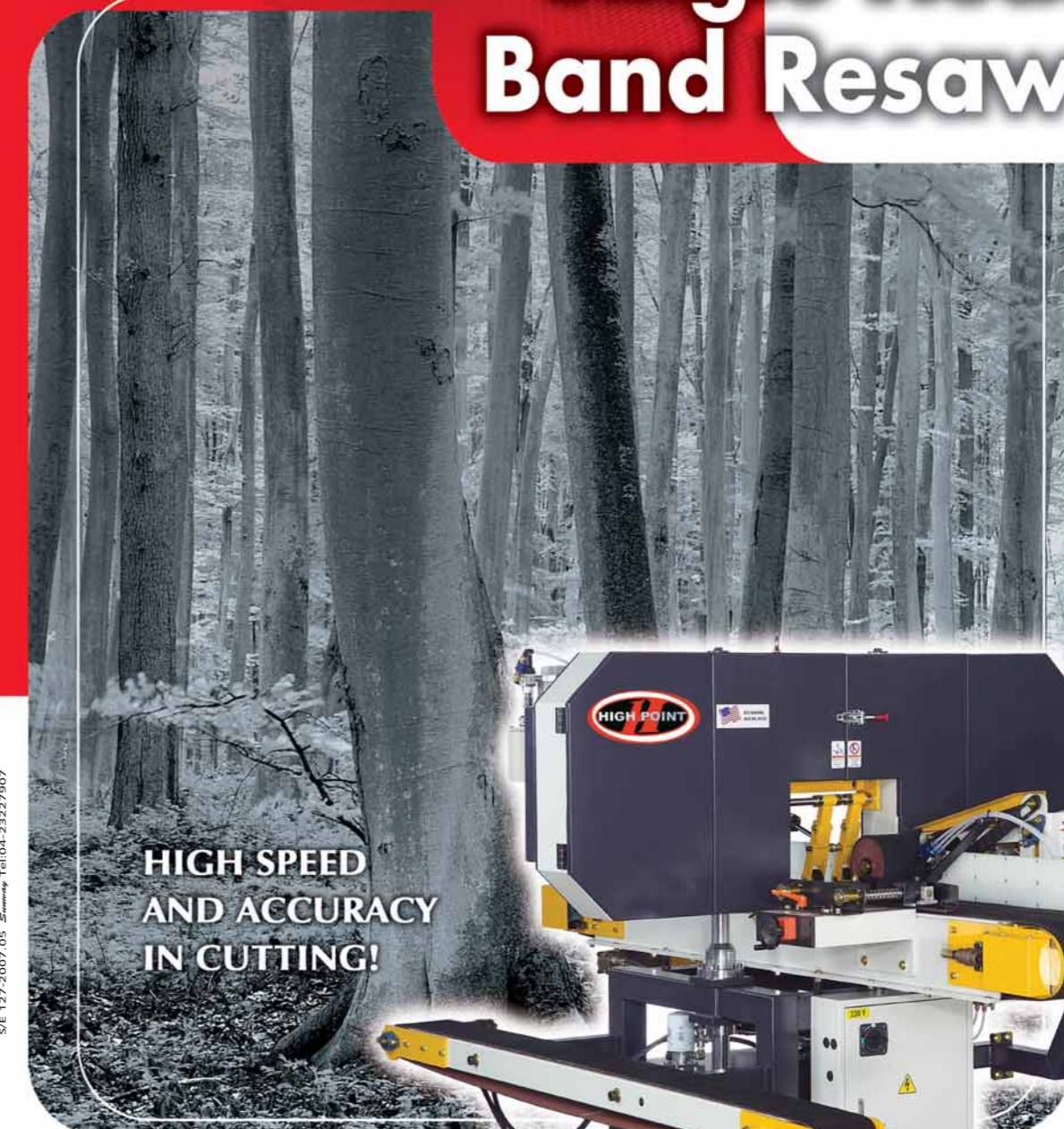

HIGH SPEED AND ACCURACY IN CUTTING!

Cutting Edge Technology for Accurate And Efficient Cutting !



HP-400P
 HP-400PB
 HP-400PB-EXTRA



Single Head Band Resaw



www.highpointinc.com

High speed and accuracy in cutting

Features: (Model HP-400P, HP-400PB)

- Digital thickness readout for quick and accurate saw blade positioning.
- Return conveyor provides convenience for repetitive cutting.
- Variable speed hydraulically driven feed and return conveyor.
- The pressure wheel is air loaded for quick and convenient pressure regulation.
- Powered saw wheel elevation.
- Automatic hydraulic blade tension control and indicator.
- Lifting wheel guard.
- Hinged wheel cover.



HP-400P, HP-400PB ▲



Outfeed Pressure Rollers (Model HP-400PB-EXTRA)

- The outfeed pressure rollers are controlled by an air cylinder. Hold down pressure is adjustable to suit wood thickness.



▲ HP-400PB - EXTRA

Outstanding Features Help You Stay Ahead : (Model HP-400PB-EXTRA)

- Infeed and outfeed fence are coated with engineering plastic for increasing smoothness of feeding.
- Reinforced machine structure to achieve better rigidity for blade tension.
- Oil mist cooling for sawblade.
- Digital thickness readout for quick and accurate saw blade positioning.
- Return conveyor provides convenience for repetitive cutting.
- Variable speed hydraulically driven feed and return conveyor.
- The pressure wheel is air loaded for quick and convenient pressure regulation.
- Powered saw wheel elevation.
- Variable wheel speed controlled by frequency inverter (optional).

SPECIFICATIONS~

MODEL	HP-400P	HP-400PB	HP-400PB-EXTRA
Max workpiece size	400mm(W) x 250mm(H)	300mm(W) x 250mm(H)	300mm(W) x 250mm(H)
Distance from blade to conveyor table	4 mm	4 mm	4 mm
Conveyor belt size	385 x 5480 mm	285 x 5480 mm	285 x 5480 mm
Saw wheel diameter	ø28" x 1"(W)	ø28" x 2"(W)	ø28" x 2"(W)
Feed speed	4-15 m/min	4-15 m/min	4-25 m/min
Saw blade size	4570 x 27 x 0.90 mm (180" x 1")	4570 x 41 x 1.27 mm (180" x 1-1/2")	4570 x 41 x 1.27 mm (180" x 2" or 1-1/2")
Saw wheel motor	30 HP	30 HP	30 HP
Hydraulic system motor	In-feed: OMP250 / Out-feed: OMP160		
Gear box motor	1/4 HP	1/4 HP	1/4 HP
Hydraulic pressure	55 kgs/cm ²	55 kgs/cm ²	55 kgs/cm ²
Dust hood diameter	ø4" x 2	ø4" x 2	ø4" x 2
Machine weight	1700 kgs	1800 kgs	1900 kgs
Packing dimensions	2870 x 2260 x 2050 mm	2870 x 2260 x 2050 mm	2870 x 2260 x 2050 mm
Optional	Inverter	Inverter	Inverter

All specifications, dimensions and design characteristics shown in this catalogue are subject to change without notice.



Specially Designed Infeed Pressure Wheel

- The infeed pressure wheel is loaded by air cylinder, that holds down workpiece firmly during cutting.



Outfeed Pressure Rollers (Model HP-400P, 400PB)

- The outfeed pressure rollers are controlled by an air cylinder. Hold down pressure is adjustable to suit wood thickness.



Increased Height of Feed Conveyor

- The height of the feed conveyor is greatly increased to maximize rigidity and stability and allows solid support for heavy wood.

- The conveyor belt running is driven by a hydraulic motor combined with transmission through chain, providing greater driving force and upgrading stability, when feeding at low speed.

Easy Smooth Infeed

- The extra large infeed pressure roller can be raised and lowered, which is operated by an air cylinder with air switch control. This provides easier and more smooth infeed motion.



Side Pressure Plate

- An additional side pressure plate is provided at the side of conveyor table, that holds wood against the infeed fence for added stability during feeding.

- The side pressure plate is spring loaded, and can be adjusted according to wood width.
- A mechanical meter allows for accurate setting of width.