

FR 1006

FAST ROTATOR[®]

PATENT PENDING

WWW.FASTROTATOR.COM



CHARACTERISTICS

- Functionality
- Loading and unloading accessibility of the device with raw material
- Work security
- Autonomous work cells
- Flexibility
- Innovative Geometry

GOALS

- Profiles rotation for following operations of positioning and welding, without the help of secondary means of production of larger size, e.g. Rolling Cranes
- Raise of productivity
- Greater autonomy of the work cells and therefore the workers

- Maximum load capacity 6 ton.
- Rotation speed 18 seg/90°
- Maximum diameter (HEA1000)
- Voltage 380v
- Adjustable height support (620mm to 860mm)
- Standard color (Red - Ral 3031/ Blue - Ral 5010)
- Other colors

WEIGHT 1800 Kg

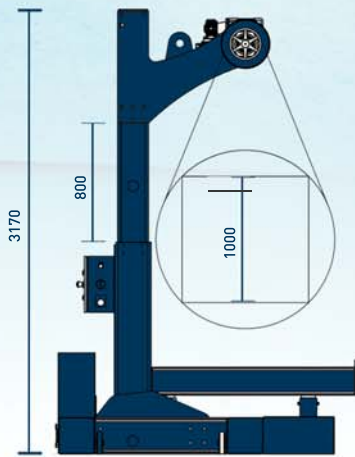

OPEN POSITION

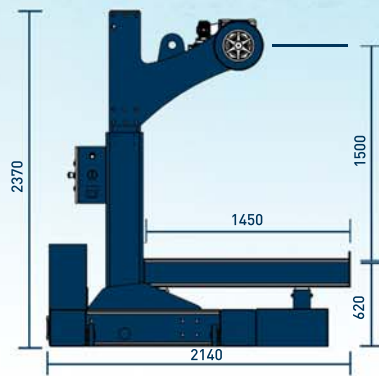

CLOSED POSITION

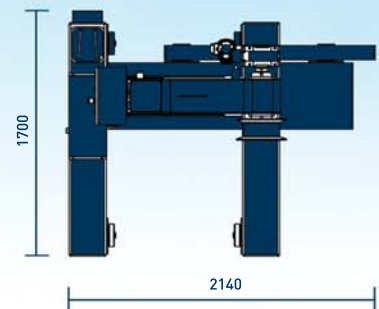

Zona Industrial de Vagos, Lote 93 | 3840-385 Vagos - PORTUGAL
T: +351 234 790 010 | F: +351 234 790 019 | E: info@fastrotator.com